

Irvine Sensors Corporation
Microelectronics Products Division

128 Mbit (8M x 16) Synchronous DRAM Memory Stack

Features:

- ❑ Low Profile: same PCB footprint as a monolithic TSOP
 - ❑ Provides a cost-effective emulation of a 128 Mbit SDRAM by using 2 low cost 64 Mbit SDRAMs.
- ❑ JEDEC Standard Pinout
 - ❑ JEDEC Standard 3.3V power supply

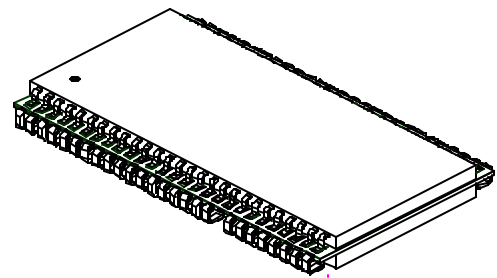
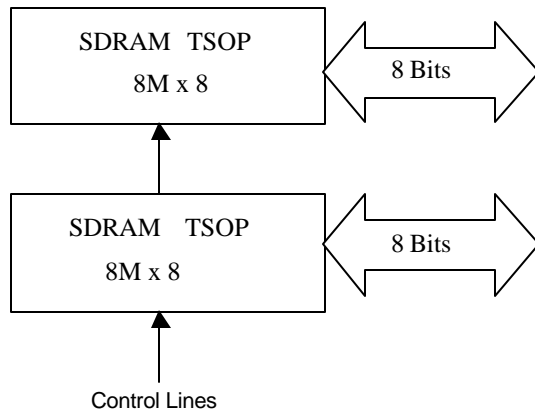

Dimensions: 0.890" L x 0.490" W x 0.100" H
(+/- 0.005" on all dimensions)

General Description

The Irvine Sensor's Microelectronics Products Division's 128 Mbit SDRAM memory stack provides a cost-effective interim alternative to the monolithic 128 Mbit SDRAM. Boards designed for the monolithic 128Mbit TSOP will also accept the 128Mbit stack interchangeably. This allows for switching between the stack and the monolithic TSOP depending on market economics without a board redesign. When the monolithic 128Mbit TSOP becomes more cost effective than the 64Mbit based stack, no modification to the board design is required. Base design uses Samsung K4S640832 TSOPs but these stacks can be manufactured using customer furnished TSOPs from a variety of manufacturers.

Application note: Do not exceed 220°C when soldering part to PCB.

For more information contact MPD Sales:

Phone 1-714-435-8291 Fax 1-714-444-8764 E-mail mpdsales@irvine-sensors.com
Irvine Sensors Corporation, 3001 Redhill Avenue, Building 3, Costa Mesa, CA 92656-4529

Irvine Sensors Corporation

Microelectronics Products Division

MPD PART NUMBERING SYSTEM

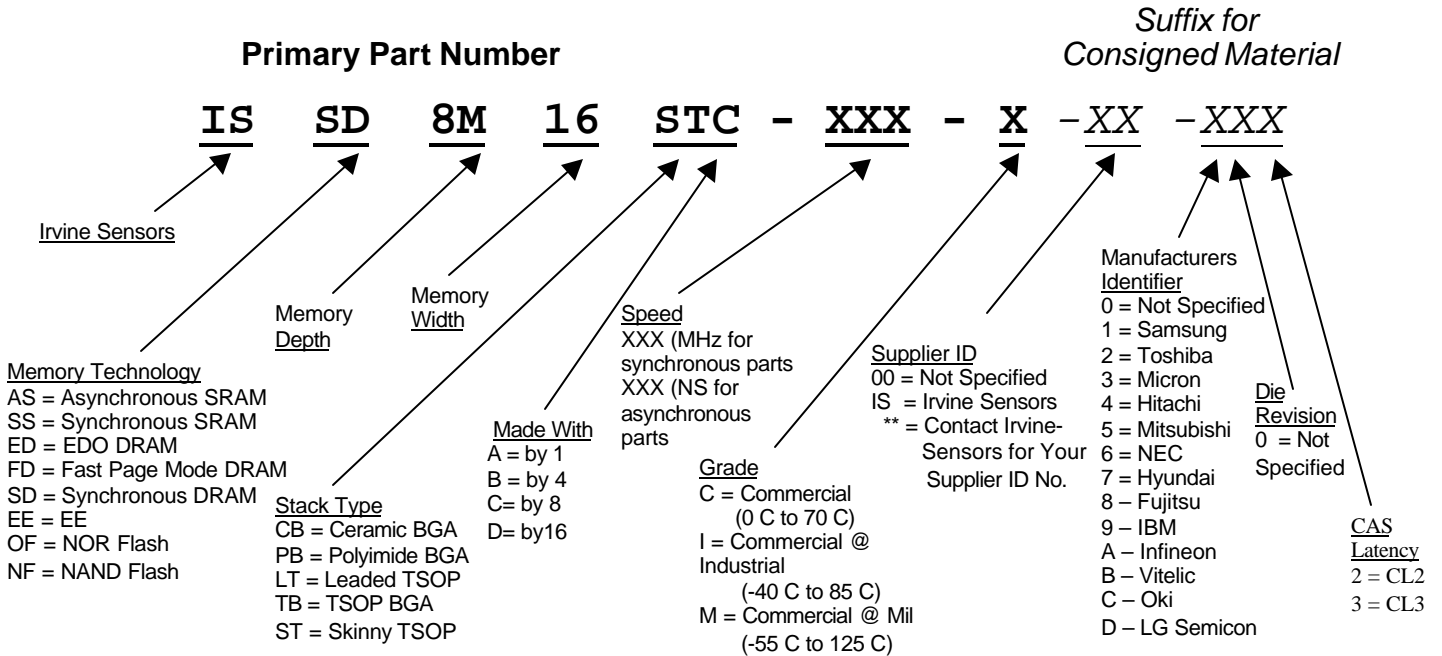

Pin Names

Pin #	Name	Name	Pin #
1	Vcc	Vss	54
2	DQ0	DQ7	53
3	Vddq	Vssq	52
4	DQ8	DQ15	51
5	DQ1	DQ6	50
6	Vssq	Vddq	49
7	DQ9	DQ14	48
8	DQ2	DQ5	47
9	Vddq	Vssq	46
10	DQ10	DQ13	45
11	DQ3	DQ4	44
12	Vssq	Vddq	43
13	DQ11	DQ12	42
14	Vdd	Vss	41
15	N/C	NC/RFU	40
16	WE	DQM	39
17	CAS	CLK	38
18	RAS	CKE	37
19	CS	N/C	36
20	BA0	A11	35
21	BA1	A9	34
22	A10/AP	A8	33
23	A0	A7	32
24	A1	A6	31
25	A2	A5	30
26	A3	A4	29
27	Vcc	Vss	28

For more information contact MPD Sales:

Phone 1-714-435-8291 Fax 1-714-444-8764 E-mail mpdsales@irvine-sensors.com
Irvine Sensors Corporation, 3001 Redhill Avenue, Building 3, Costa Mesa, CA 92656-4529