

*Irvine Sensors Corporation*  
Microelectronics Products Division

## 256 Mbit (64M x 4) Synchronous DRAM Memory Stack

### Features:

- Low Profile: same PCB footprint as a monolithic TSOP
- Provides a cost-effective emulation of a 256 Mbit SDRAM by using 2 low cost 128 Mbit SDRAMs.
- Low cost, economical for volume commercial applications
- JEDEC Standard 3.3V power supply

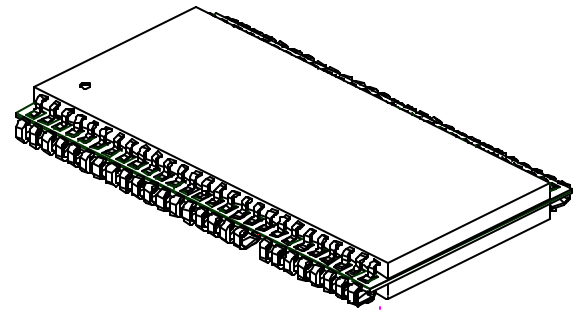
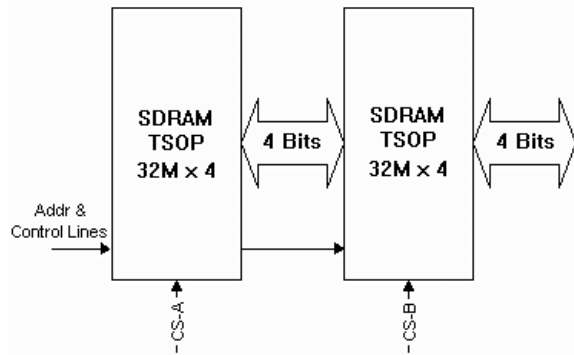

Dimensions: 0.890”L x 0.490”W x 0.100”H  
(+/- 0.005” on all dimensions)

### General Description

The Irvine Sensor's Microelectronics Products Division's 256 Mbit SDRAM memory stack provides a cost-effective interim alternative to the monolithic 256 Mbit SDRAM. Boards can be designed to accept either the monolithic 128Mbit TSOP or the 256Mbit stack interchangeably. This allows for a generation upgrade without a board redesign. When the monolithic 256Mbit TSOP becomes more cost effective than the 128Mbit based stack, minor modification to the board design can make it compatible with either the monolithic 256Mbit TSOP or the 512Mbit stack. Base design uses Samsung K4S280438 TSOPs but these stacks can be manufactured using customer furnished TSOPs from a variety of manufacturers.

Application note: Do not exceed 220°C when soldering part to PCB.

For more information contact MPD Sales:

**Phone 1-714-435-8291    Fax 1-714-444-8764    E-mail [mpdsales@irvine-sensors.com](mailto:mpdsales@irvine-sensors.com)**  
Irvine Sensors Corporation, 3001 Redhill Avenue, Building 3, Costa Mesa, CA 92656-4529

*This document contains preliminary information on a product under development. IRVINE SENSORS CORPORATION reserves the right to change product specifications or discontinue this product without prior notice. All trademarks and/or registered trademarks are properties of their respective companies. © 1998 Irvine Sensors Corporation. All rights reserved. 3/99*

# Irvine Sensors Corporation

## Microelectronics Products Division

### MPD PART NUMBERING SYSTEM

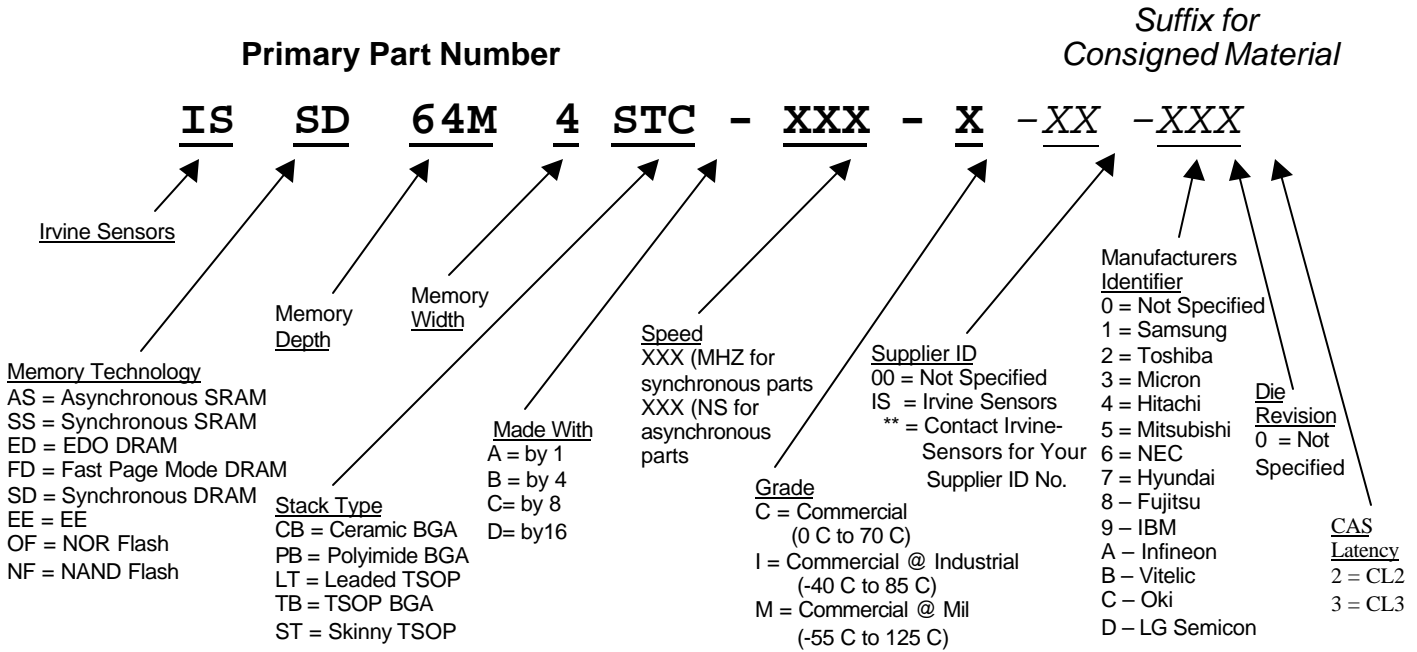

### Pin Names

Pin #	Name	Name	Pin #
1	Vcc	Vss	54
2	N/C	N/C	53
3	Vddq	Vssq	52
4	N/C	N/C	51
5	DQ0	DQ3	50
6	Vssq	Vddq	49
7	N/C	N/C	48
8	N/C	N/C	47
9	Vddq	Vssq	46
10	N/C	N/C	45
11	DQ1	DQ2	44
12	Vssq	Vddq	43
13	N/C	N/C	42
14	Vdd	Vss	41
15	CS-B	NC/RFU	40
16	WE	DQM	39
17	CAS	CLK	38
18	RAS	CKE	37
19	CS-A	N.C.	36
20	BA0	A11	35
21	BA1	A9	34
22	A10/AP	A8	33
23	A0	A7	32
24	A1	A6	31
25	A2	A5	30
26	A3	A4	29
27	Vcc	Vss	28

For more information contact MPD Sales:

Phone 1-714-435-8291 Fax 1-714-444-8764 E-mail [mpdsales@irvine-sensors.com](mailto:mpdsales@irvine-sensors.com)

Irvine Sensors Corporation, 3001 Redhill Avenue, Building 3, Costa Mesa, CA 92656-4529