

Irvine Sensors Corporation
Microelectronics Products Division

256Mbit (16M x 16) DDR DRAM Memory Stack

Features:

- ❑ Low Profile: same PCB footprint as a monolithic TSOP
- ❑ Provides a cost-effective emulation of a 256 Mbit DDR DRAM by using 2 low cost 128 Mbit DDR DRAMs.
- ❑ JEDEC Standard 3.3V power supply

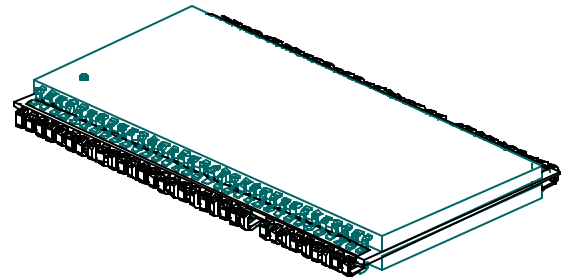
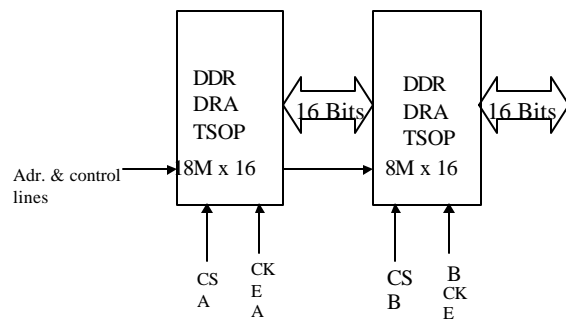

Dimensions: 0.890”L x 0.490”W x 0.100”H
(+/- 0.005” on all dimensions)

- ❑ Low cost, economical for volume commercial applications

General Description

The Irvine Sensor's Microelectronics Products Division's 256Mbit DDR DRAM memory stack provides a cost-effective interim alternative to the monolithic 256Mbit DDR DRAM. Boards can be designed to accept either the monolithic 128Mbit TSOP or the 256Mbit stack interchangeably. This allows for a generation upgrade without a board redesign. When the monolithic 256Mbit TSOP becomes more cost effective than the 128Mbit based stack, minor modification to the board design can make it compatible with either the monolithic 256Mbit TSOP or the 512Mbit stack. Base design uses Samsung K4H281638 TSOPs but these stacks can be manufactured using customer furnished TSOPs from a variety of manufacturers.

Application note: Do not exceed 220°C when soldering part to PCB.

For more information contact MPD Sales:

Phone 1-714-435-8291 Fax 1-714-444-8764 E-mail mpdsales@irvine-sensors.com

Irvine Sensors Corporation, 3001 Redhill Avenue, Building 3, Costa Mesa, CA 92656-4529

IRVINE SENSORS CORPORATION reserves the right to change product specifications or discontinue this product without prior notice. All trademarks and/or registered trademarks are properties of their respective companies. © 1998 Irvine Sensors Corporation. All rights reserved.

Irvine Sensors Corporation

Microelectronics Products Division

MPD PART NUMBERING SYSTEM

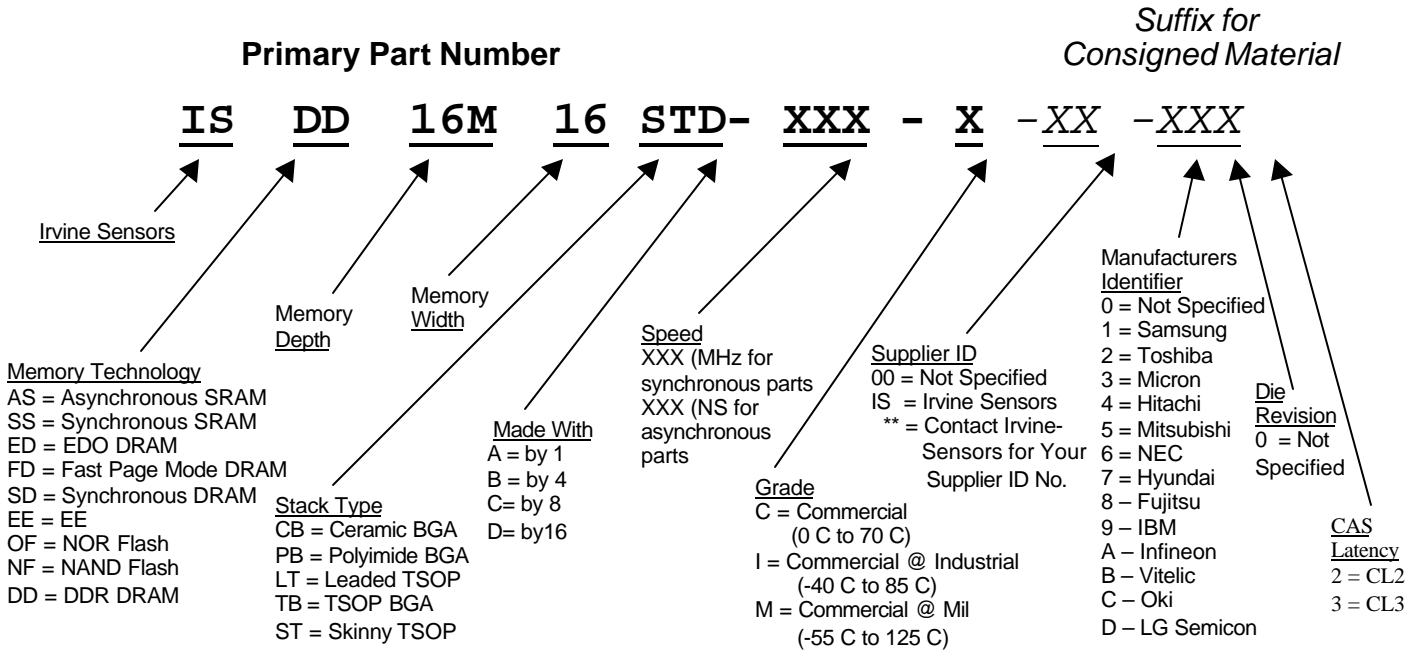

Pin Names

Pin #	Name	Name	Pin #
1	Vdd	Vss	66
2	Dq0	DQ15	65
3	Vddq	Vssq	64
4	DQ1	DQ14	63
5	DQ2	DQ13	62
6	Vssq	Vddq	61
7	DQ3	DQ12	60
8	DQ4	DQ11	59
9	Vddq	Vssq	58
10	DQ5	DQ10	57
11	DQ6	DQ9	56
12	Vssq	Vddq	55
13	DQ7	DQ8	54
14	NC	NC	53
15	Vddq	Vssq	52
16	NC	DQS	51
17	NC	NC	50
18	Vdd	Vref	49
19	NC	Vss	48
20	NC	DM	47
21	WE	CK	46
22	CAS	CK	45
23	RAS	CKE A	44
24	CS A	CKE B	43
25	CS B	NC	42
26	BA0	A11	41
27	BA1	A9	40
28	AP/A10	A8	39
29	A0	A7	38
30	A1	A6	37
31	A2	A5	36
32	A3	A4	35
33	Vdd	Vss	34

For more information contact MPD Sales:

Phone 1-714-435-8291 Fax 1-714-444-8764 E-mail mpdsales@irvine-sensors.com

Irvine Sensors Corporation, 3001 Redhill Avenue, Building 3, Costa Mesa, CA 92656-4529

IRVINE SENSORS CORPORATION reserves the right to change product specifications or discontinue this product without prior notice. All trademarks and/or registered trademarks are properties of their respective companies. © 1998 Irvine Sensors Corporation. All rights reserved. 5/01